

CLAMPING AND BRAKING ELEMENTS SERIES UBPS

▶ PRODUCT ADVANTAGES

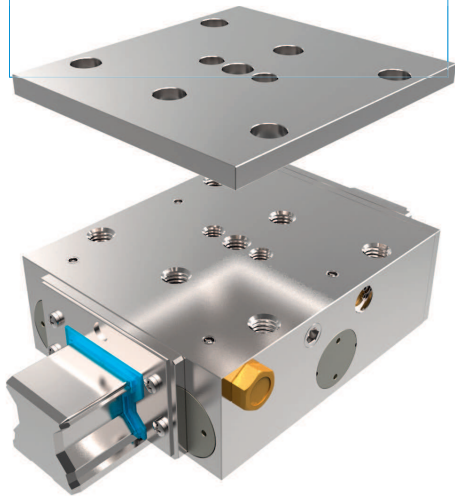

- ▶ **broad range of products**
For all common profile rail guides
- ▶ **Energize to open (NC)**
through spring-loaded energy storage
- ▶ **high durability**
Up to 5 million static clamping cycles
- ▶ **Higher clamping forces**
Via activation with PLUS air
- ▶ **Safety element**
Safe braking in case of energy failure

▶ INFORMATION ON THE PRODUCTS

APPLICATION SCENARIOS

- ▶ **Emergency OFF function**
- ▶ **Z-axes positioning in neutral position**
- ▶ **Machine table clamping of work centre**

FURTHER INFORMATION

- ▶ **Adapter plate**
In addition, an adapter plate might have to be ordered as height compensation depending on the height of the runner block (dimension D).
- ▶ **Special variants on request, e.g.**
With proximity switch monitoring
With low opening pressure (3.0 bar or 4.0 bar)
With additional air connection (from above, from the front)

▶ TECHNICAL DETAILS

- ① **Profile rail guide**
- Available for all common profile rail guides
- ② **Wedge-type gear**
- Power transmission between the pistons and clamping jaws and brake shoes
- ③ **Clamping jaws and brake shoes**
- Pressed at the free surfaces of the profile rail guide
- ④ **housing**
- chemically nickel plated steel
- ⑤ **Pneumatic piston**
- The piston moves the wedge-type gear longitudinally
- ⑥ **Spring-loaded energy storage**
- For non-pressurized closing of the clamping unit
- ⑦ **Scraper**
- Can also be ordered as an option

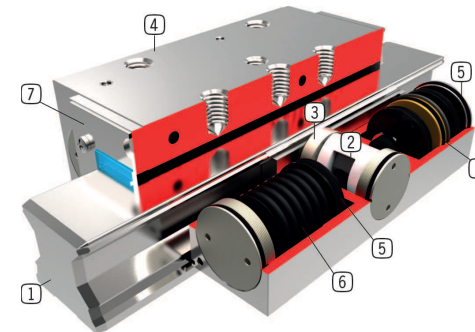

▶ INFORMATION ON THE SERIES

TECHNICAL DATA

Rail size	20-65 mm
Holding force	1500-9200
pressure min.	5.5
pressure max.	6
Spring-loaded energy storage	existing
PLUS connection	yes
Clamping cycles	up to 5 million
Braking cycles	up to 2000
Operation	pneumatic

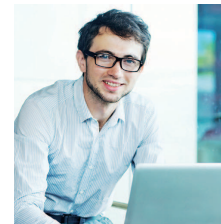

▶ Technical Information

All information just a click away at: www.zimmer-group.de
Find data, illustrations, 3D models and operating instructions for your installation size using the order number for your desired product.
Quick, clear and always current.